

# Vacuum Fluorescent Display Module

## Hardware Specification

Model: GU384X32L-3xxx series  
(GU384X32L-3xx0, 3xx1 series)

Specification No:	DS-954-0005-04
Date Of Issue:	February 11, 2003 (00)
Revision:	March 03, 2003 (01) April 25, 2003 (02) September 18, 2003 (03) February 21, 2005 (04)

Published by  
NORITAKE ITRON Corp. / Japan  
<http://www.noritake-itron.jp/>

This specification is subject to change without prior notice.

Index.

<b>1</b>	<b>General Description</b> .....	<b>2</b>
1.1	Scope.....	2
1.2	Construction.....	2
1.3	Outline.....	2
1.4	Block Diagram.....	3
1.4.1	For 3xx0 series.....	3
1.4.2	For -3xx1 series.....	3
<b>2</b>	<b>General Purpose I/O port</b> .....	<b>4</b>
<b>3</b>	<b>Electrical specification</b> .....	<b>4</b>
3.1	Absolute Maximum Ratings.....	4
3.2	Electrical ratings.....	5
3.3	Electrical Characteristics.....	5
<b>4</b>	<b>Optical Specifications</b> .....	<b>7</b>
<b>5</b>	<b>Environmental Specifications</b> .....	<b>7</b>
<b>6</b>	<b>Interface</b> .....	<b>8</b>
6.1	Type of interface.....	8
6.2	Interface timing.....	8
6.2.1	RS-232 Asynchronous serial interface timing.....	8
6.2.2	Parallel interface timing.....	9
6.2.3	USB Interface timing.....	9
<b>7</b>	<b>Setup</b> .....	<b>9</b>
7.1	DIP-Switch (SW1).....	9
<b>8</b>	<b>Connector</b> .....	<b>10</b>
8.1	For -3xx0 Series.....	10
8.1.1	Power connector (CN6).....	10
8.1.2	RS-232 Interface & Power connector (CN2).....	10
8.1.3	Parallel interface & Power connector (CN5).....	10
8.1.4	I/O Port connector (CN1).....	10
8.2	For -3xx1 Series.....	11
8.2.1	Power connector (CN6).....	11
8.2.2	USB connector (CN4).....	11
8.2.3	I/O Port connector (CN1).....	11
8.3	Connectors.....	12
8.3.1	For -3xx0 series.....	12
8.3.2	For -3xx1 series.....	12
<b>9</b>	<b>Outline Drawing</b> .....	<b>13</b>
9.1	For -3xx0 series.....	13
9.2	For -3xx1 series.....	14
	<b>Notice for the Cautious Handling VFD Modules</b> .....	<b>15</b>
	<b>Revision Note</b> .....	<b>16</b>

# 1 General Description

## 1.1 Scope

This specification covers the hardware and its requirements of the vacuum fluorescent graphic display module GU384X32L-3xx0,3xx1 series.

## 1.2 Construction

The module consists of a 384 x 32dot graphic BD-VFD, refresh RAM, character generator, DC/DC converter, display controller, and all necessary control logic. The module can simultaneously display graphic patterns and/or characters on the screen.

## 1.3 Outline

Power supply: + 5 V<sub>DC</sub> (VCC1) & + 24 V<sub>DC</sub> (VCC2)  
 Interface: **3xx0 Series:** Parallel interface, RS-232 Asynchronous Serial interface  
**3xx1 Series:** USB interface (USB 1.1 compatible)  
 I/O port: 12bits General purpose I/O port available  
           8bit Input/Output port (Port 0), 4bit Input port (Port 1)  
 Protocol: Direct mode  
           Packet mode  
 Function: Character display  
           Graphic display  
           Control command  
           Display action command  
           Draw command  
           Window function  
           General Purpose I/O port control  
           Macro, Program Macro function  
           Character and Bit Image download function  
           Memory SW

For more detail;

Refer to specification:

DS-954-0012-xx: for 384x32dot, -31xx series "General function" software spec

DS-954-0010-xx: for 384x32dot, -39xx series "General function" software spec

DS-954-0003-xx: "Program Macro" software spec

## 1.4 Block Diagram

### 1.4.1 For 3xx0 series

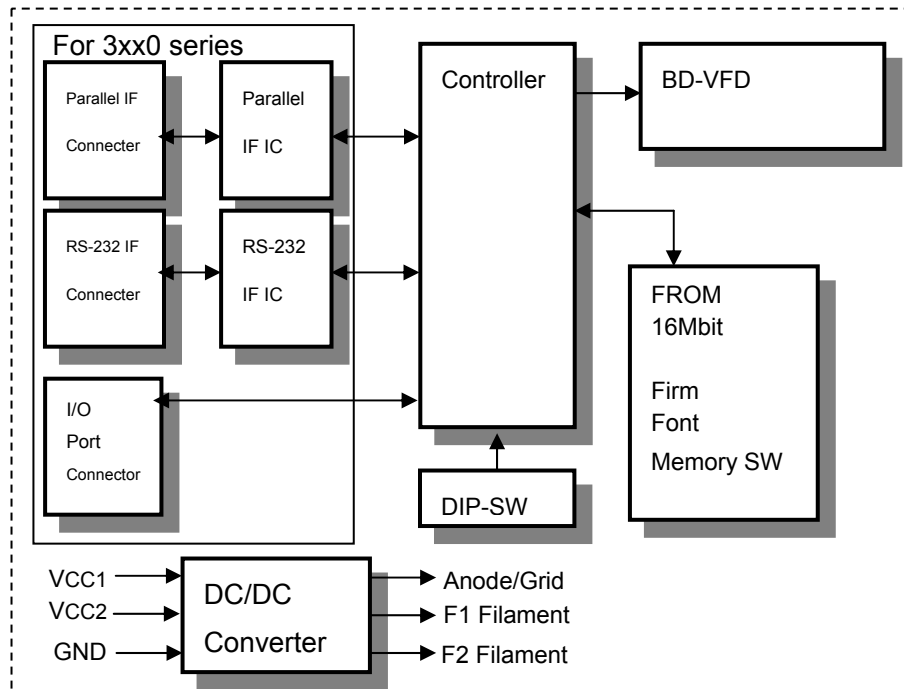

### 1.4.2 For -3xx1 series

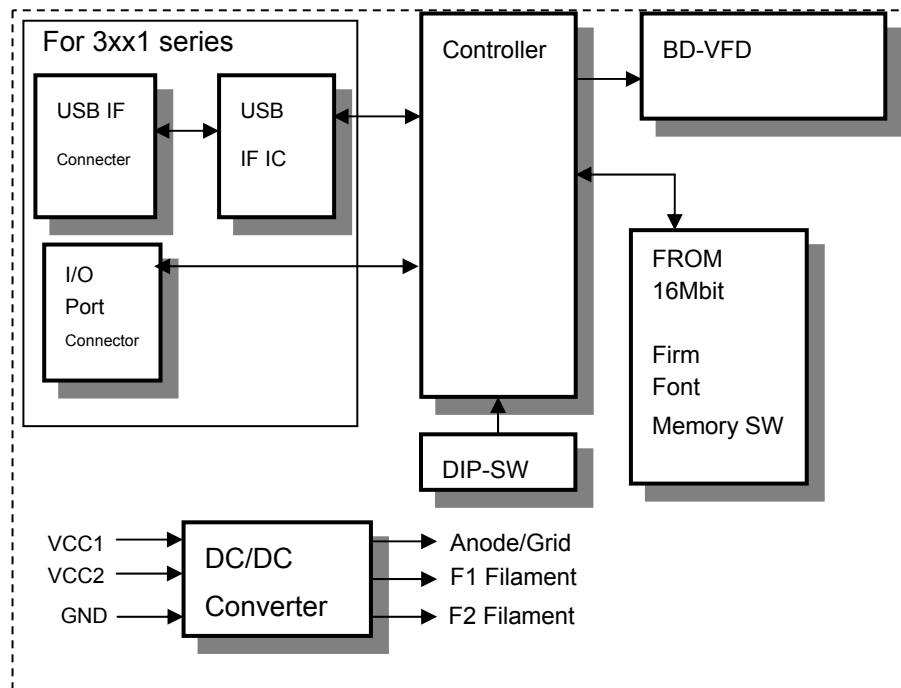

Please note that the re-writable time of the FROM is approximately 100,000 times.

## 2 General Purpose I/O port

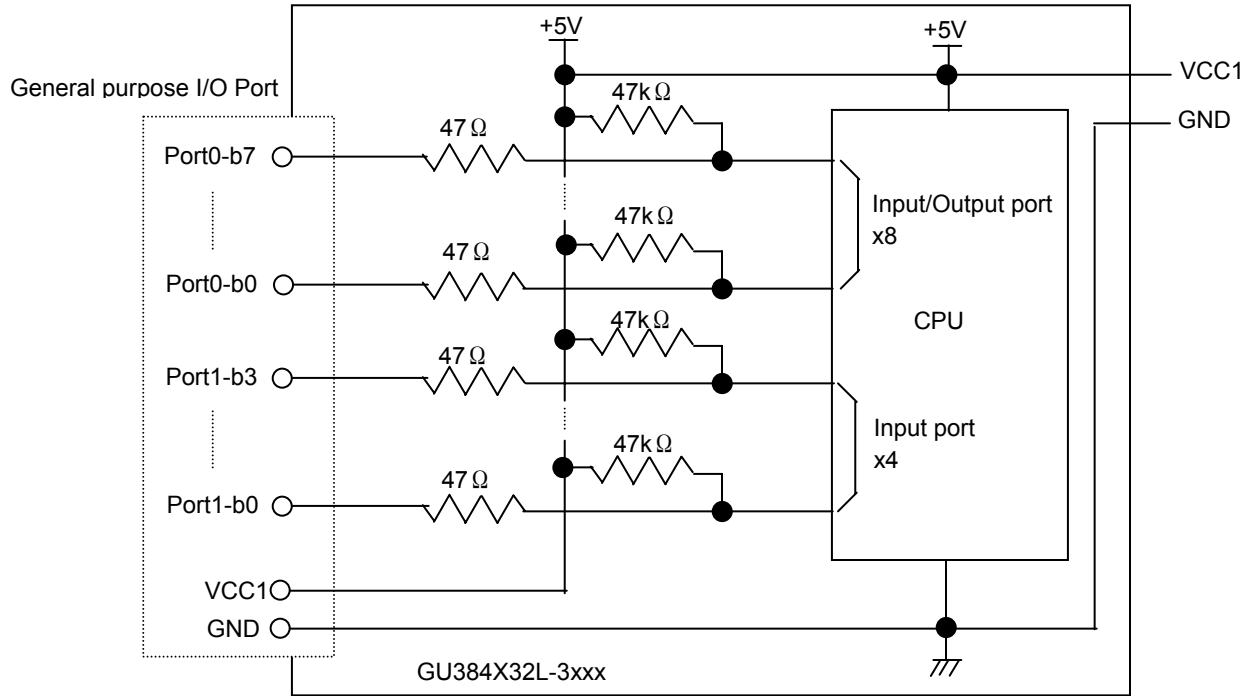

Refer to 3.3 Electrical Characteristics “General purpose I/O port supply Voltage for -3xx0, -3xx1 series.”  
 For controlling, refer to 384x32dot “General function” software spec., “I/O Port Input/Output setting”, “I/O Port Output”, “I/O Port Input”.

## 3 Electrical specification

### 3.1 Absolute Maximum Ratings

#### Power Supply Voltage for -3xx0, -3xx1 series.

Parameter	Symbol	Min.	Typ.	Max.	Unit	Note
Power Supply Voltage	VCC1	-0.3	-	+6.0	VDC	-
	VCC2	-0.3		+28.0	VDC	-

#### Logic Supply Voltage for -3xx0 series.

Parameter	Symbol	Min.	Typ.	Max.	Unit	Note
Parallel I/F D0 -D7 /WR	VpIN	-0.3	-	Vcc+0.3	VDC	
RS-232 Serial I/F RXD, DSR	VsIN	-25		+25	VDC	

#### Logic Supply Voltage for -3xx1 series.

Parameter	Symbol	Min.	Typ.	Max.	Unit	Note
USB I/F D+, D-		USB 1.1 compatible				

#### I/O port supply Voltage for -3xx0, -3xx1 series.

Parameter	Symbol	Min.	Typ.	Max.	Unit	Note
I/O port Port 0, Port 1	ViIN	-0.3	-	Vcc+0.3	VDC	

### 3.2 Electrical ratings

#### Power Supply Voltage for -3xx0, -3xx1 series.

Parameter	Symbol	Min.	Typ.	Max.	Unit	Note
Power Supply Voltage	VCC1	4.75	5.0	5.25	VDC	-
	VCC2	22.8	24.0	25.2	VDC	-

All driving voltage for the VFD is converted from the DC/DC converter on board.

### 3.3 Electrical Characteristics

#### Logic input/output condition for -3xx0 series.

Measuring Conditions: Ambient temperature = 25degrees, VCC1 =5.0VDC, VCC2 =24.0VDC

Parameter		Symbol	Min.	Typ.	Max.	Unit	Condition	Note
Parallel I/F	Logic input current D0 - D7, /WR	I <sub>pIH</sub>	-	-	1.0	uADC	-	-
		I <sub>pIL</sub>	-	-	-200	uADC	-	-
	Logic input voltage D0 - D7, /WR	V <sub>pIH</sub>	0.8VCC		VCC	VDC	-	-
		V <sub>pIL</sub>	0		0.2VCC	VDC	-	-
	Logic output voltage RDY	V <sub>pOH</sub>	3.5		VCC	VDC	IOH=-10uA	(1)
		V <sub>pOL</sub>	0		0.6	VDC	IOL=4mA	
RS-232 I/F	Logic input voltage RXD, DSR	V <sub>sIH</sub>	3	-	15	VDC	-	-
		V <sub>sIL</sub>	-15	-	-3	VDC	-	-
	Logic output voltage TXD, DTR	V <sub>sOH</sub>	5	-	-	VDC	RL=3KΩ	-
		V <sub>sOL</sub>	-	-	-5	VDC		-
	Logic input Impedance RXD, DSR	R <sub>sIN</sub>	3	-	7	K Ω		-

(1) "RDY" is open collector terminal. (Pull up by 47Kohm)

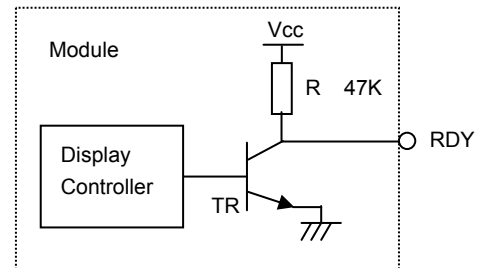

#### Logic input/output condition for -3xx1 series.

Measuring Conditions: Ambient temperature = 25degrees, VCC1 =5.0VDC, VCC2 =24.0VDC

Parameter		Symbol	Min.	Typ.	Max.	Unit	Condition	Note
USB I/F	Logic input/output voltage D+, D-	USB 1.1 compatible						

**General purpose I/O port supply Voltage for -3xx0, -3xx1 series.**

Measuring Conditions: Ambient temperature = 25degrees, VCC1 =5.0VDC, VCC2 =24.0VDC

Parameter		Symbol	Min.	Typ.	Max.	Unit	Condition	Note
General purpose I/O port	Logic input current Port 0, 1	IiIH	-	-	1.0	uADC	-	-
		IiIL	-	-	-200	uADC	-	-
	Logic input voltage Port 0	ViIH	2.0	-	VCC	VDC	-	-
		ViIL	0	-	0.8	VDC	-	-
	Logic output voltage Port 0	ViOH	VCC-0.6	-	-	VDC	IOH=-200uA	-
		ViOL	-	-	0.5	VDC	IOL=1.6mA	
	Logic input voltage Port 1 (Schmidt Trigger input)	ViT-	1.0	-	-	VDC	-	-
		ViT+	-	-	0.7VCC	VDC	-	-
ViT+ - ViT-		0.4	-	-	VDC	-	-	

**General purpose I/O port output permissible current for -3xx0, -3xx1 series.**

Measuring Conditions: Ambient temperature = 25degrees, VCC1 =5.0VDC, VCC2 =24.0VDC

Parameter		Symbol	Min.	Typ.	Max.	Unit	Condition	Note
General purpose I/O port	Output permissible current Port 0, 1 (per 1 terminal)	IiOH	-	-	1.5	mADC	-	-
		IiOL	-	-	8	mADC	-	-
	Output permissible current Port 0, 1 (The Sum of all I/O terminal)	IiOH	-	-	8	mADC	-	-
		IiOL	-	-	30	mADC	-	-

**Output current should not be exceeded from the value of above table.**

**In case of driving the LED or some other device directly, please be sure to insert current limiter into an output line.**

**Power Supply condition for -3xx0 series.**

Measuring Conditions: Ambient temperature = 25degrees, VCC1 =5.0VDC, VCC2 =24.0VDC

Parameter	Symbol	Min.	Typ.	Max.	Unit	Condition	Note
Power Supply Current 1	ICC1	-	80	120	mADC		
Power Supply Current 2	ICC2-1		650	850	mADC		(2)
	ICC2-2	-	480	630	mADC		(3)

**Power Supply condition for -3xx1 series.**

Measuring Conditions: Ambient temperature = 25degrees, VCC1 =5.0VDC, VCC2 =24.0VDC

Parameter	Symbol	Min.	Typ.	Max.	Unit	Condition	Note
Power Supply Current 1	ICC1	-	90	140	mADC		
Power Supply Current 2	ICC2-1		650	850	mADC		(2)
	ICC2-2	-	480	630	mADC		(3)

Note

(2),(3) ICC2-1 shows the current at all dots in the screen are lighted and ICC2-2 at all dots off. At power on rush, more than 2times current of above table should be expected. Provide the quick rise type power supply (<100msec.).

The power supply current at the Display power OFF specified by the Display power ON/OFF command will be only power supply current 1 (ICC1). Refer to 384x32dot "General function" software spec., "Display power ON/OFF" command.

#### 4 Optical Specifications

Number of dots:	12288 (384 x 32)
PCB Size:	551.0 mm x 91.0 mm (X x Y)
Display area:	468.21mm x 50.28mm(X x Y)
Dot size:	0.95mm x 1.3mm(X x Y)
Dot pitch:	1.22mm x 1.58mm (X x Y)
Luminance:	300cd/m <sup>2</sup> Min.
Color of illumination:	Green (Blue Green)

#### 5 Environmental Specifications

Operating temperature:	-40 to +70degrees C (-20 to +70 degrees C in case of -3xx1 series)
Storage temperature:	-40 to +85degrees C
Storage humidity:	20 to 80 % R.H(Non Condensing)
Vibration:	10-55-10Hz, all amplitude 1mm, 30Min., X-Y-Z (Non operating)
Shock:	392m/s <sup>2</sup> (40G) 9mS X-Y-Z (Non operating)



## 6 Interface

### 6.1 Type of interface

The following interfaces are available on this module;  
 -3xx0 series: Parallel interface, RS-232 Serial interface  
 -3xx1 series: USB (USB 1.1 Compatible)

### 6.2 Interface timing

#### 6.2.1 RS-232 Asynchronous serial interface timing

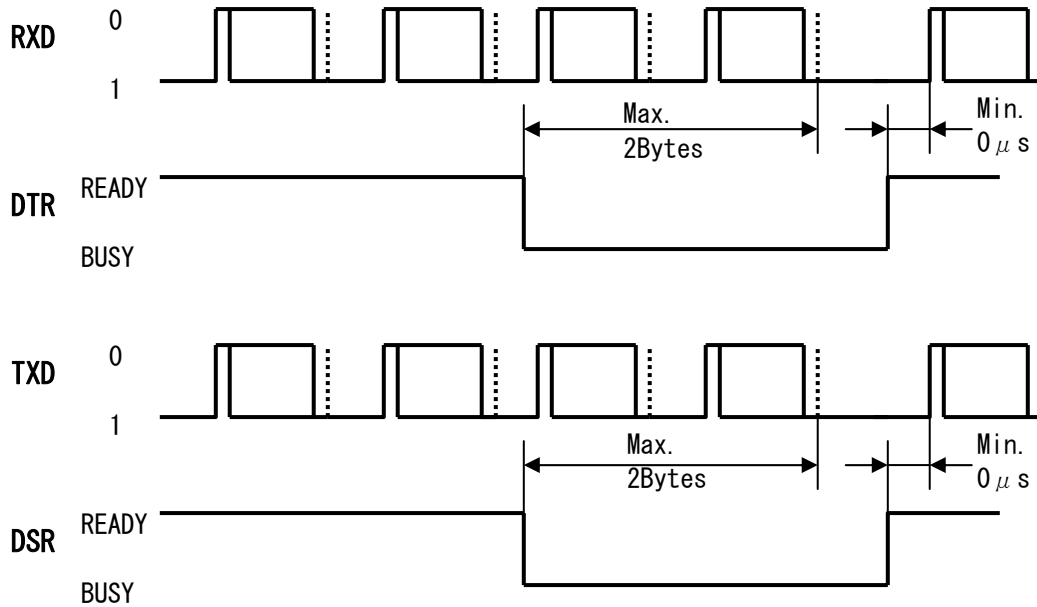

The above timing is RS-232 level. The logical value is inverted from above level.

Interface:

<b>Baud rate</b>	19,200 or 38,400bps (Selectable by DIP SW)
<b>Parity</b>	Non parity
<b>Format</b>	Start (1bit)+Data (8bit)+(Parity)+Stop (1bit)
<b>Handshake</b>	DTR, DSR

Buffer Capacity

<b>Receiving buffer</b>	256byte
<b>Sending buffer</b>	128byte

DTR signal change timing

<b>DTR change</b>	1 (Ready)→0(Busy)	0(Busy) →1(Ready)
<b>Condition</b>	When the rest of receiving buffer or sending buffer size less than 32bytes.	When the rest of receiving buffer and sending buffer size more than 64bytes.

### 6.2.2 Parallel interface timing

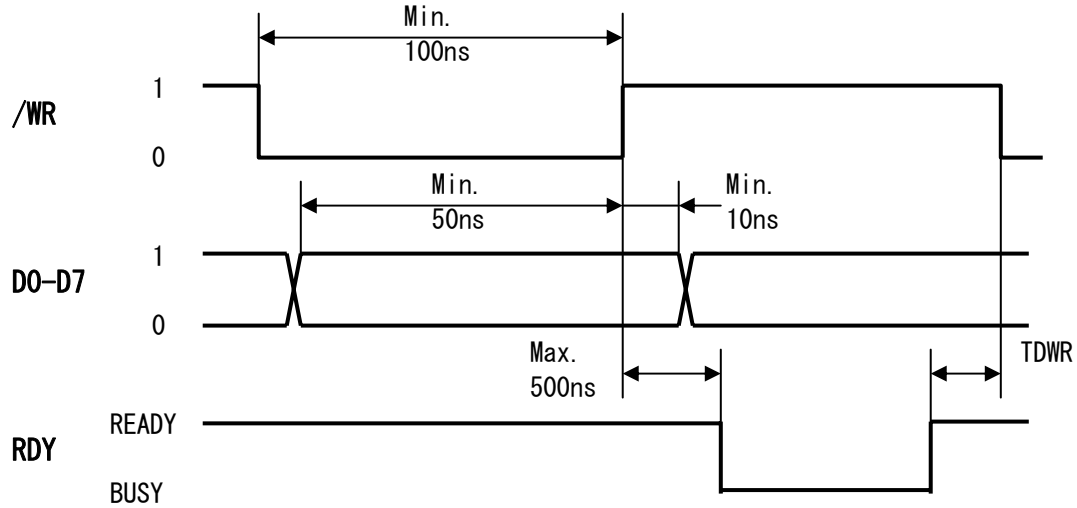

TDWR = Normal command mode: Min 1  $\mu$  S  
 Graphic DMA Mode: Min 15  $\mu$  S  
 \*RDY=0(BUSY) is output every 1 byte.

This module has 256 bytes of receiving buffer internally, and after data is inputted, RDY signal is set to RDY=0(BUSY) until it is stored into the receiving buffer. If data is inputted when receiving buffer is full, RDY signal is set to RDY=0(BUSY) until space for 1 byte will be available in receiving buffer. It changes, and is variable depending on the command contents, or data writing frequency at user side.

Due to above reason, RDY line should be always checked for data writing.

### 6.2.3 USB Interface timing

USB 1.1 Compatible, Refer to USB 1.1 standard.

## 7 Setup

### 7.1 DIP-Switch (SW1)

SW No.	Function	Default
1	Display address select (For multi connection)	Off
2		Off
3		Off
4		Off
5	Baud Rate select	Off
6	Command mode select	Off
7	Operating Mode select	Off
8	Protocol select	Off

Detail of setup for DIP SW, refer to 384x32dot "General function" software spec., "Setup"

## 8 Connector

### 8.1 For -3xx0 Series

#### 8.1.1 Power connector (CN6)

Pin No.	Signal name	Function	Direction
1	VCC1	Power supply (5V)	Input
2	GND	Ground	Input
3	VCC2	Power supply (24V)	Input
4	GND	Ground	Input
5	TEST *	Test (Factory use only)	Input

\* Internally connected. (Be sure to leave this pin open)

#### 8.1.2 RS-232 Interface & Power connector (CN2)

Pin No.	Signal name	Function	Direction
1	RXD	Data receive	Input
2	DTR	Display busy	Output
3	DSR	Host busy	Input
4	TXD	Data send	Output
5	NC	Non connection	-
6	VCC1	Power supply (5V)	Input
7	GND	Ground	Input

#### 8.1.3 Parallel interface & Power connector (CN5)

Pin No.	Signal name	Function	Direction	Pin No.	Signal name	Function	Direction
1	D7	Data input	Input	2	D6	Data input	Input
3	D5	Data input	Input	4	D4	Data input	Input
5	D3	Data input	Input	6	D2	Data input	Input
7	D1	Data input	Input	8	D0	Data input	Input
9	GND	Ground	Input	10	/WR	Data write	Input
11	GND	Ground	Input	12	RDY	Display READY	Output
13	GND	Ground	Input	14	GND	Ground	Input
15	VCC	Power supply (5V)	Input	16	VCC	Power supply (5V)	Input

#### 8.1.4 I/O Port connector (CN1)

Pin No.	Signal name	Function	Direction	Pin No.	Signal name	Function	Direction
1	Bit7	Input/Output Port 0	Input/Output	8	Bit0	Port 0	Input/Output
2	Bit6			Input Port 1	Input		
3	Bit5						
4	Bit4						
5	Bit3						
6	Bit2			13	VCC1	Power supply (5V)	Input
7	Bit1			14	GND	Ground	Input

## 8.2 For -3xx1 Series

### 8.2.1 Power connector (CN6)

Pin No.	Signal name	Function	Direction
1	VCC1	Power supply (5V)	Input
2	GND	Ground	Input
3	VCC2	Power supply (24V)	Input
4	GND	Ground	Input
5	TEST *	Test (Factory use only)	Input

\* Internally connected. (Be sure to leave this pin open)

### 8.2.2 USB connector (CN4)

Pin No.	Signal name	Function	Direction
1	Vbus *	VBus	Input
2	D+	+ Data	Input/Output
3	D-	- Data	Input/Output
4	GND	Ground	Input

The power supply from Vbus can not be used for power supply for module driving.  
The power supply for module driving should be inputted from Power connector.

### 8.2.3 I/O Port connector (CN1)

Pin No.	Signal name	Function	Direction	Pin No.	Signal name	Function	Direction		
1	Bit7	Input/Output Port 0	Input/Output	8	Bit0	Port 0	Input/Output		
2	Bit6			9	Bit3	Input Port 1	Input		
3	Bit5			10	Bit2				
4	Bit4			11	Bit1				
5	Bit3			12	Bit0	13	VCC1	Power supply (5V)	Input
6	Bit2			14	GND	Ground	Input		
7	Bit1								

### 8.3 Connectors

#### 8.3.1 For -3xx0 series

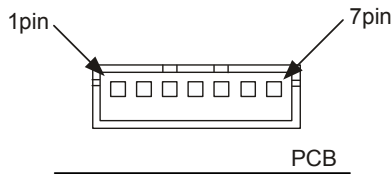

**RS-232 I/F connector**  
JST: B7B-XH-A or equivalent

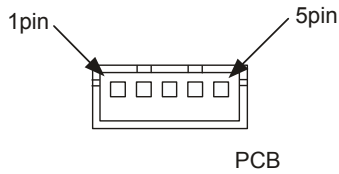

**Power connector**  
JST: B5B-XH-A or equivalent

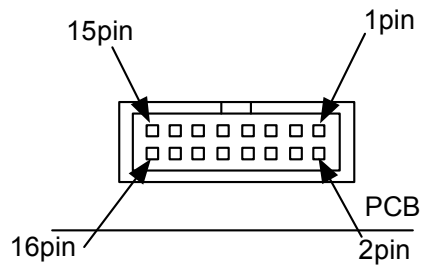

**Parallel I/F connector**  
IRISO: IMSA-9032B-16P or Equivalent

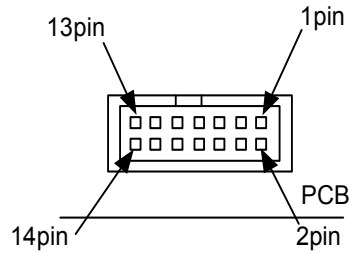

**I/O port connector**  
IRISO: IMSA-9032B-14P or Equivalent

#### 8.3.2 For -3xx1 series

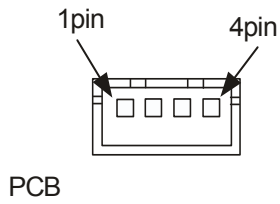

**USB connector**  
JST: B4B-XH-A or equivalent

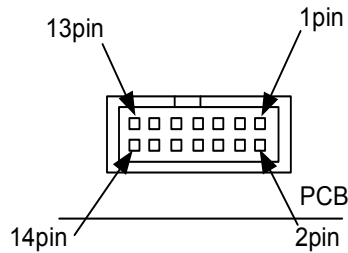

**I/O port connector**  
IRISO: IMSA-9032B-14P or Equivalent

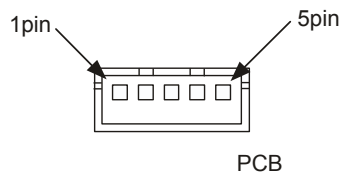

**Power connector**  
JST: B5B-XH-A or equivalent

## 9 Outline Drawing

### 9.1 For -3xx0 series

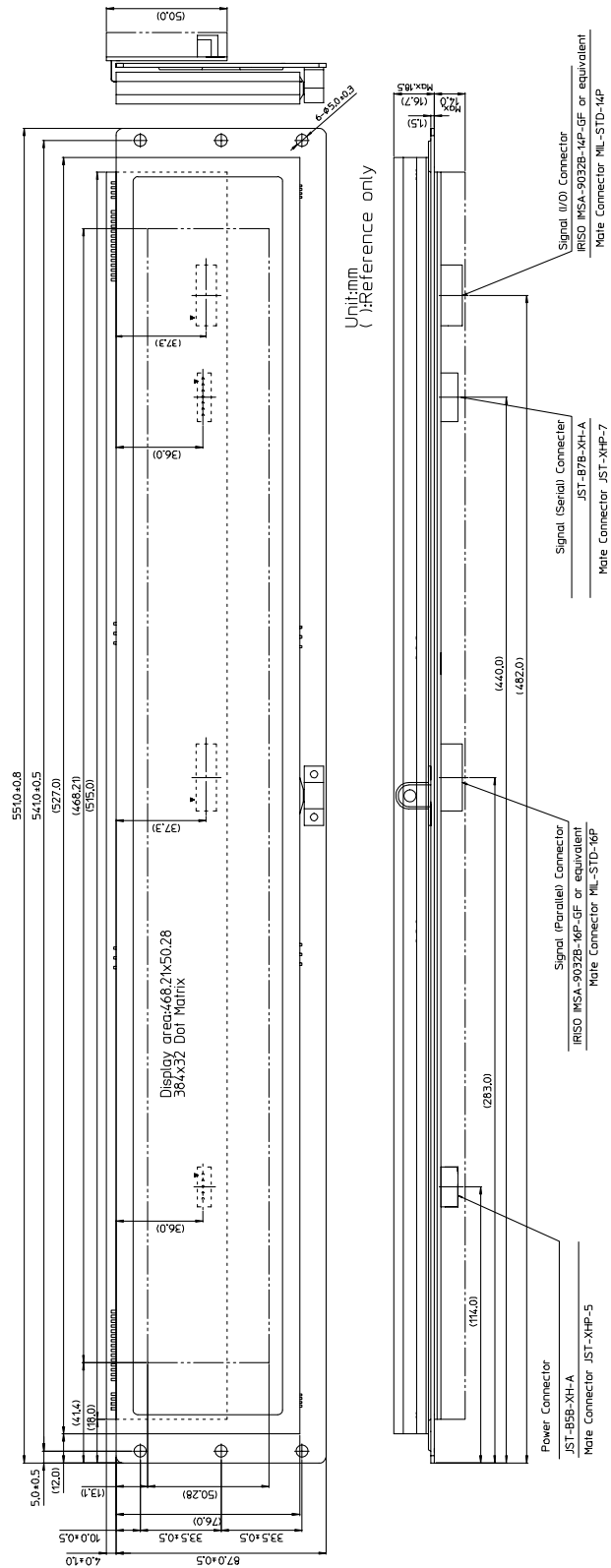

9.2 For -3xx1 series

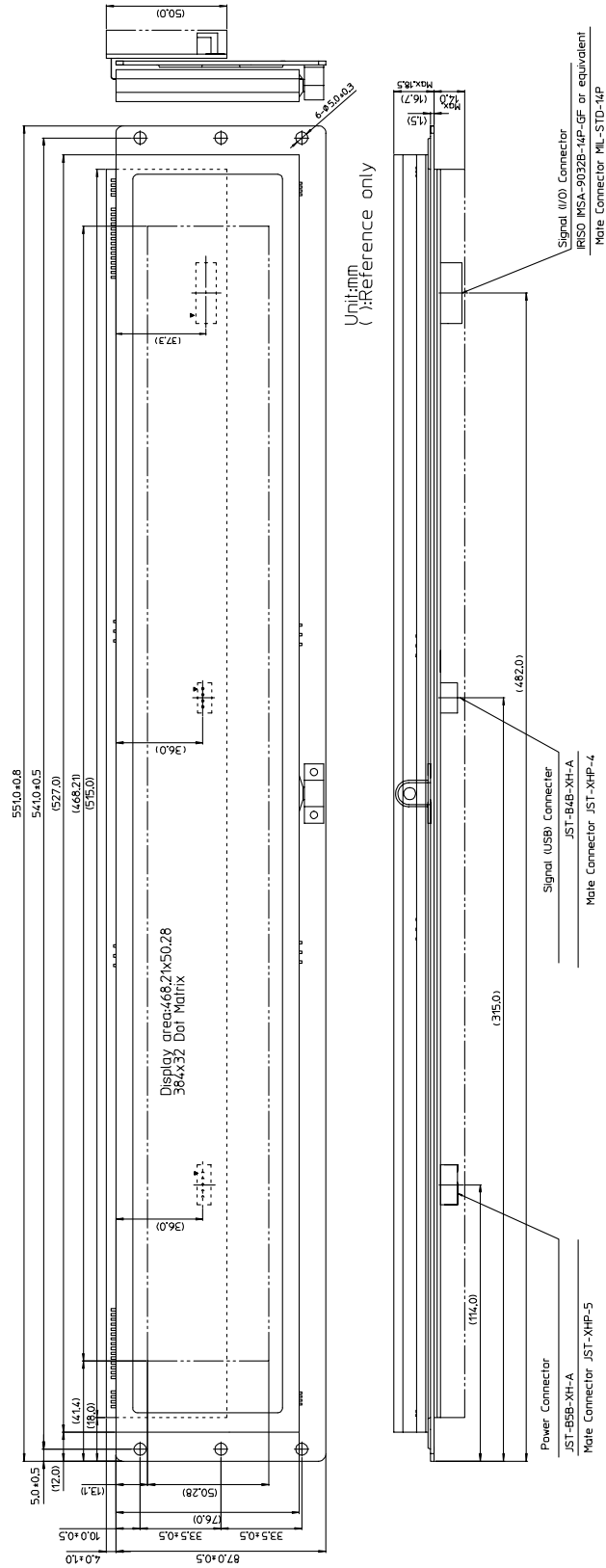

## Notice for the Cautious Handling VFD Modules

### Handling and Usage Precautions:

Please carefully follow the appropriate product application notes for proper usage, safety handling, and operation standards for maximum performance.

#### [VFD tubes are made of glass]

- Because the edges of the VFD glass-envelop are not smooth, it is necessary to handle carefully to avoid injuries to your hands
- Please avoid breaking the VFD glass-envelop to prevent injury from sharp glass particles.
- The tip of the exhaust pipe is fragile so avoid shock from impact.
- It is recommended to allow sufficient open space surrounding the exhaust pipe to avoid possible damage.
- Please design the PCB for the VFD-module within 0.3 mm warping tolerance to avoid any forces that may damage the display due to PCB distortion causing a breakdown of the electrical circuit leading to VFD failure.

#### [High voltage]

- Avoid touching conductive electrical parts, because the VFD-module uses high voltage exceeding 30~100 volts.
- Even when electric power is turned off, it may take more than one minute for the electrical current to discharge.

#### [Cable connection]

- Do not unplug the power and/or data cables of VFD-modules during operating condition because unrecoverable damage may result.
- Sending input signals to the VFD-module during a power off condition sometimes causes I/O port damage.
- It is recommended to use a 30 cm or shorter signal cable to prevent functional failures.

#### [Electrostatic charge]

- VFD-modules need electrostatic free packaging and protection from electrostatic charges during handling and usage.

#### [Structure]

- During operation, VFD and VFD-modules generate heat. Please consider sufficient heat radiation dissipation using heat sink solutions.
- We prefer to use UL grade materials or components in conjunction with VFD-modules.
- Wrap and twist motion causes stress and may break VFDs & VFD modules. Please adhere to allowances within 0.3mm at the point of attachment.

#### [Power]

- Apply regulated power to the VFD-module within specified voltages to protect from failures.
- Because some VFD-modules may consume in rush current equal to twice the typical current at power-on timing, we recommend using a sufficient power capability and quick starting of the power regulator.
- VFD-module needs a specified voltage at the point of connection. Please use an adequate power cable to avoid a decrease in voltage. We also recommend inserting a power fuse for extra protection.

#### [Operating consideration]

- Illuminating phosphor will decrease in brightness during extended operation. If a fixed pattern illuminates for an extended period,( several hours), the phosphor efficiency will decrease compared to the non operating phosphor causing a non uniform brightness among pixels. Please consider programming the display patterns to use all phosphor segments evenly. Scrolling may be a consideration for a period of time to refresh the phosphor condition and improve even illumination to the pixels.
- We recommend using a signal cable 30cm or less to avoid some possible disturbances to the signal.

#### [Storage and operating environment]

- Please use VFD-modules under the recommended specified environmental conditions. Salty, sulfur and dusty environments may damage the VFD-module even during storage.

#### [Discard]

- Some VFDs contain a small amount of cadmium in the phosphor and lead in the solder. When discarding VFDs or VFD-modules, please adhere to governmental related laws or regulations.

#### [Others]

- Although the VFD-module is designed to be protected from electrical noise, please plan your circuitry to exclude as much noise as possible.
- Do not reconstruct or repair the VFD-module without our authorization. We cannot assure the quality or reliability of unauthorized reconstructed VFD-modules.

#### Notice:

- We do not authorize the use of any patents that may be inherent in these specifications.
- Neither whole nor partial copying of these specifications are permitted without our approval.  
If necessary , please ask for assistance from our sales consultant.
- This product is not designed for military, aerospace, medical or other life-critical applications. If you choose to use this product for these applications, please ask us for prior consultation or we cannot take responsibility for problems that may occur.



**Revision Note**

SPEC number	Date	Revision
DS-954-0001-04	Feb. 21,2005	8.2.2 Pin Assingment has been corrected. Incorrect      Correct 1. VBUS            VBUS 2. D-              D+ 3. D+              D- 4. GND            GND