

**VACUUM FLUORESCENT DISPLAY**  
**MODULE**  
**SPECIFICATION**

MODEL : CU20025-UW1J

SPECIFICATION NO. : DS-1515-0000-01

DATE OF ISSUE : March 27, 2008 (00R)

R E V I S I O N : September 4, 2009 (00)

: May 25, 2010 (01)

:  
:

PUBLISHED BY

NORITAKE ITRON CORP. / JAPAN

<http://www.noritake-itron.jp>

This specification is subject to change without prior notice.

**This product complies with RoHS Directive 2002/95/EC**

## Index

1	General Description .....	2
1.1	Application.....	2
1.2	Construction.....	2
1.3	Scope.....	2
1.4	Weight.....	2
2	Absolute Maximum Ratings .....	2
3	Electrical Ratings.....	2
4	Electrical Characteristics .....	3
5	Optical Characteristics.....	3
6	Environmental Conditions.....	3
7	Functional Descriptions.....	4
7.1	Instruction table .....	4
7.2	Display Clear .....	6
7.3	Cursor Home.....	6
7.4	Entry Mode Set .....	6
7.5	Display ON/OFF.....	7
7.6	Cursor/Display Shift .....	8
7.7	Function Set.....	8
7.7.1	Function Set Command.....	8
7.7.2	Brightness Control.....	9
7.8	Set CG RAM Address.....	9
7.9	Set DD RAM Address.....	9
7.10	Write Data.....	10
7.11	Read Data.....	10
7.12	Read Busy Flag/Address Counter .....	10
8	Other features .....	11
8.1	CG RAM.....	11
8.2	Power-on reset .....	12
8.3	CPU interface.....	12
8.3.1	Select CPU .....	12
8.3.2	4-bit CPU interface.....	12
8.3.3	Serial data transfer.....	13
8.4	Jumper.....	14
9	Character Font .....	15
9.1	Katakana character font.....	15
9.2	International character font .....	16
10	Timing .....	17
10.1	CPU bus write timing (Parallel interface i80 type) .....	17
10.2	CPU bus read timing (Parallel interface i80 type).....	17
10.3	CPU bus write timing (Parallel interface M68 type).....	18
10.4	CPU bus read timing (Parallel interface M68 type) .....	18
10.5	Write timing (Serial interface) .....	19
10.6	Read timing (Serial interface) .....	19
11	Connector Pin assignment .....	20
11.1	14pin Connector (CN1) for parallel interface .....	20
11.2	6pin Connector (CN3) for serial interface.....	20
12	Outline dimension .....	21
	Notice for the Cautious Handling VFD Modules .....	22

## 1 General Description

- 1.1 Application : Readout of computer, micro-computer, communication terminal and automatic instruments.
- 1.2 Construction : Single board display module consists of 40 characters (2×20) VFD, a controller which includes character generator ROM, RAM and DC/DC converter.
- 1.3 Scope : Interface is 8/4 bit parallel and synchronous serial.  
+5V single power supply is required.
- 1.4 Weight : About 40 g

## 2 Absolute Maximum Ratings

Parameter	Symbol	Min.	Typ.	Max.	Unit	Condition
Power Supply Voltage	$V_{CC}$	0	–	5.5	$V_{DC}$	–
Logic Input Voltage	$V_I$	0	–	$V_{CC}+0.3$	$V_{DC}$	–

## 3 Electrical Ratings

Measuring Conditions: TA (Ambient temperature) = 25 degree

Parameter	Symbol	Min.	Typ.	Max.	Unit	Condition
Logic Input Voltage DB0-DB7, RS, $R/\overline{W}(\overline{WR})$ , E( $\overline{RD}$ ), SCK, STB	"H"	$V_{IH1}$	2.0	–	$V_{CC}$	$V_{DC}$ $V_{CC} - V_{SS}$ = 5.0V
	"L"	$V_{IL1}$	$V_{SS}$	–	0.8	
Logic Input Voltage SI/SO	"H"	$V_{IH2}$	$0.7V_{CC}$	–	$V_{CC}$	$V_{DC}$ $V_{CC} - V_{SS}$ = 5.0V
	"L"	$V_{IL2}$	$V_{SS}$	–	$0.3V_{CC}$	
Logic Input Voltage /RESET	"H"	$V_{IH3}$	$0.8V_{CC}$	–	$V_{CC}$	$V_{DC}$ $V_{CC} - V_{SS}$ = 5.0V
	"L"	$V_{IL3}$	$V_{SS}$	–	$0.2V_{CC}$	
Power supply Voltage	$V_{CC}-V_{SS}$	4.75	5.00	5.25	$V_{DC}$	–

Note: "/RESET" must be driven by open-collector or open-drain because this module has an internal Reset-IC.

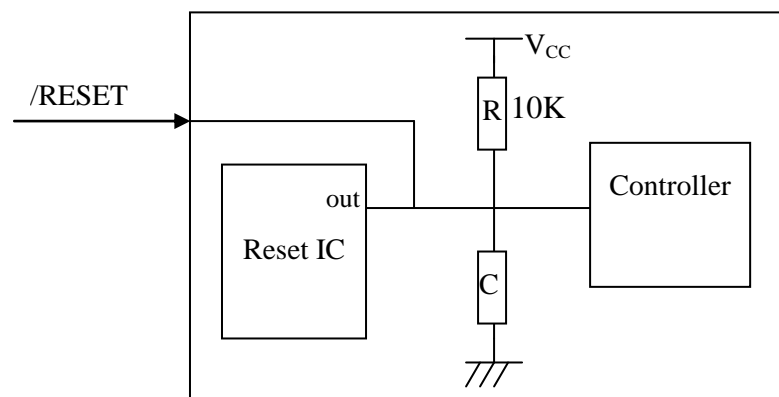

Configuration of Reset-IC peripheral circuit.

## 4 Electrical Characteristics

Measuring Conditions: TA (Ambient temperature) = 25degree,  $V_{CC} = 5.0V_{DC}$ 

Parameter	Symbol	Min.	Typ.	Max.	Unit	Condition	
Logic Output Voltage	"H"	$V_{OH}$	$V_{CC}-0.8$	–	–	$V_{DC}$	$I_{OH} = -4 \text{ mA}$
	"L"	$V_{OL}$	–	–	0.6		$I_{OL} = 4 \text{ mA}$
	"H"	$V_{OH}$	$V_{CC}-0.5$	–	–	$V_{DC}$	$I_{OH} = -2 \text{ mA}$
	"L"	$V_{OL}$	–	–	0.5		$I_{OL} = 2 \text{ mA}$
Power Supply Current 1	$I_{CC1}$	–	140	200	mA	Display ON	
Power Supply Current 2	$I_{CC2}$	–	3	10	mA	Display OFF	
Power Consumption		–	0.7	1.0	W	Display ON	

Note:  $I_{CC1}$  shows the current, when all dots are turned on. $I_{CC}$  might be anticipated twice as usual at power on rush.

## 5 Optical Characteristics

Number of characters	: 40 (2 lines×20 chars)
Matrix format	: 5×7 dot with underline
Display area	: 70.8×11.5 mm (X×Y)
Character size	: 2.4×4.7 mm (X×Y) Underline is not included.
Character pitch	: 3.6 mm
Line pitch	: 6.1 mm
Dot size	: 0.4×0.5 mm (X×Y)
Dot pitch	: 0.5×0.7 mm (X×Y)
Luminance	: 350 cd/m <sup>2</sup> (100fL) Min.
Color of illumination	: Green (Blue-green)

## 6 Environmental Conditions

Operating temperature	: -40 to +85 degree
Storage temperature	: -50 to +85 degree
Operating humidity	: 20 to 80 % RH (Non condensation)
Vibration (Non operation)	: 10 to 55 to 10 Hz (Frequency) 1.0 mm (Total Amplitude) 30 Min. (Duration) X, Y, Z each direction
Shock (Non operation)	: 539 m/s <sup>2</sup> , 10ms

## 7 Functional Descriptions

## 7.1 Instruction table

Instruction	CODE										Time	Description	
	RS	R/W	DB7	DB6	DB5	DB4	DB3	DB2	DB1	DB0			
Display Clear	0	0	0	0	0	0	0	0	0	0	1	100μs MAX.	Clears all display and sets DD RAM address 0 in the address counter.
Cursor Home	0	0	0	0	0	0	0	0	0	1	*	666ns	Sets DD RAM address 0 in the address counter. Also returns the display being shifted to the original position. DD RAM contents remain unchanged.
Entry Mode Set	0	0	0	0	0	0	0	0	1	I/D	S	666ns	Sets the cursor direction and specifies display shift. These operations are performed during writing/reading data.
Display ON/OFF Control	0	0	0	0	0	0	0	1	D	C	B	666ns	Sets all display ON/OFF(D), cursor ON/OFF(C), cursor blink of character position (B).
Cursor or Display Shift	0	0	0	0	0	0	1	S/C	R/L	*	*	666ns	Shifts display or cursor, keeping DD RAM contents.
Function Set	0	0	0	0	0	1	IF	*	*	*	*	666ns	Sets data length (IF).
Brightness Control	1	0	*	*	*	*	*	*	*	BR1	BR0	666ns	Accepts 1 byte data of just after "Function set" as brightness control data.

Instruction	CODE										Time	Description
	RS	R/ $\overline{W}$	DB7	DB6	DB5	DB4	DB3	DB2	DB1	DB0		
CG RAM Address setting	0	0	0	1	ACG						666ns	Sets the CG RAM address.
DD RAM Address setting	0	0	1	ADD						666ns	Sets the DD RAM address.	
Busy flag & Address Reading	0	1	BF	ACC						666ns	Reads busy flag (BF) and address counter.	
Data Writing to CG or DD RAM	1	0	Data writing						666ns	Writes data into CG RAM or DD RAM.		
Data Reading from CG or DD RAM	1	1	Data reading						666ns	Reads data from CG RAM or DD RAM.		
	I/D = 1 : Increment                      IF = 1 : 8-bits I/D = 0 : Decrement                    IF = 0 : 4-bits S = 1 : Display shift enabled        BF = 1 : Busy S = 0 : Cursor shift enabled        BF = 0 : Not busy S/C = 1 : Display shift S/C = 0 : Cursor move R/L = 1 : Shift to the right R/L = 0 : Shift to the left BR1, BR0 = 00 : 100% 01 : 75% 10 : 50% 11 : 25%											DD RAM: Display Data RAM CG RAM: Character Generator RAM ACG: CG RAM Address ADD: DD RAM Address ACC: Address Counter

Note:

\*: Don't care.

## 7.2 Display Clear

DB7	DB6	DB5	DB4	DB3	DB2	DB1	DB0	
0	0	0	0	0	0	0	1	01H

RS=0

This instruction

1. Fills all locations in the display data (DD) RAM with 20H (Blank character).
2. Clears the contents of the address counter to 0H.
3. Sets the display for zero character shift.
4. Sets the address counter to point to the DD RAM.
5. If the cursor is displayed, the cursor moves to the left most character in the top line (Line 1).
6. Sets the address counter to increment on each access of DD RAM or CG RAM.

## 7.3 Cursor Home

DB7	DB6	DB5	DB4	DB3	DB2	DB1	DB0	
0	0	0	0	0	0	1	*	02H to 03H

RS=0

\*: Don't care.

This instruction

1. Clears the contents of the address counter to 0H.
2. Sets the address counter to point to the DD RAM.
3. Sets the display for zero character shift.
4. If the cursor is displayed, moves the left most character in the top line (Line 1).

## 7.4 Entry Mode Set

DB7	DB6	DB5	DB4	DB3	DB2	DB1	DB0	
0	0	0	0	0	1	I/D	S	04H to 07H

RS=0

The I/D bit selects the way in which the contents of the address counter are modified after every access to DD RAM or CG RAM.

I/D=1: The address counter is increment.

I/D=0: The address counter is decrement.

The S bit enables display shifts instead of cursor shift, after each write or read to the DD RAM.

S=1: Display shift enabled.

S=0: Cursor shift enabled.

The direction in which the display is shifted is opposite in sense to that of the cursor. For example if S=0 and I/D=1, the cursor would shift one character to the right after a CPU writes to DD RAM. However if S=1 and I/D=1, the display would shift one character to the left and the cursor would maintain its position on the panel.

The cursor will already be shifted in the direction selected by I/D during reads of the DD RAM, irrespective of the value of S. Similarly reading and writing the CG RAM always shifts the cursor. Also both lines are shifted simultaneously.

#### Cursor move and Display shift by the "Entry Mode Set"

I/D	S	After writing DD RAM data	After reading DD RAM data
0	0	The cursor moves one character to the left.	The cursor moves one character to the left.
1	0	The cursor moves one character to the right.	The cursor moves one character to the right.
0	1	The display shifts one character to the right without cursor's move.	The cursor moves one character to the left.
1	1	The display shifts one character to the left without cursor's move.	The cursor moves one character to the right.

### 7.5 Display ON/OFF

DB7	DB6	DB5	DB4	DB3	DB2	DB1	DB0	
0	0	0	0	1	D	C	B	08H to 0FH

RS=0

This instruction controls various features of the display.

The D bit turns the entire display on or off.

D=1: Display on

D=0: Display off

Note: When display is turned off, power converter is also inhibited and reduces a power consumption.

The C bit turns the cursor on or off.

C=1: Cursor on

C=0: Cursor off

The B bit enables blinking of the character the cursor coincides with.

B=1: Blinking on

B=0: Blinking off

Blinking is achieved by alternating between a normal and all on display of a character.

The cursor blinks with a frequency of about 1Hz and DUTY 50%.



## 7.6 Cursor/Display Shift

DB7	DB6	DB5	DB4	DB3	DB2	DB1	DB0	
0	0	0	1	S/C	R/L	*	*	10H to 1FH

RS=0

\*: Don't care.

This instruction shifts the display and/or moves the cursor, on character to either left or right, without neither reading nor writing DD RAM.

The S/C bit selects movement of the cursor or movement of both the cursor and the display.

S/C=1: Shift both cursor and display.

S/C=0: Shift cursor only.

The R/L bit selects left ward or right ward movement of the display and/or cursor.

R/L=1: Shift one character right.

R/L=0: Shift one character left.

Cursor move and Display shift by the "Cursor/Display Shift"

S/C	R/L	Cursor shift	Display shift
0	0	Move one character to the left	No shift
0	1	Move one character to the right	No shift
1	0	Shift one character to left with display	Shift one character to the left
1	1	Shift one character to right with display	Shift one character to the right

## 7.7 Function Set

This command sets width of data bus line by itself, and sets screen brightness by following one byte data.

### 7.7.1 Function Set Command

DB7	DB6	DB5	DB4	DB3	DB2	DB1	DB0	
0	0	1	IF	*	*	*	*	20H to 3FH

RS=0

\*: Don't care.

This instruction initializes the system, and must be the first instruction executed after power-on.

The IF bit selects between an 8-bit or a 4-bit bus width interface.

IF=1: 8-bit CPU interface using DB7 to DB0

IF=0: 4-bit CPU interface using DB7 to DB4

When serial interface is selected, IF=1.

## 7.7.2 Brightness Control

DB7	DB6	DB5	DB4	DB3	DB2	DB1	DB0	
*	*	*	*	*	*	BR1	BR0	00H to 03H

RS=1

\*: Don't care.

One byte data (RS=1) which follows the "Function Set Command" is considered as brightness data. When a command (RS=0) is written after the "Function Set Command", the brightness control function is not initiated. Screen brightness is as follows.

BR1	BR0	Brightness
-----	-----	-----
0	0	100 % (Default)
0	1	75 %
1	0	50 %
1	1	25 %

## 7.8 Set CG RAM Address

DB7	DB6	DB5	DB4	DB3	DB2	DB1	DB0	
0	1	ACG						40H to 7FH

RS=0

This instruction

1. Loads a new 6-bit address into the address counter.
2. Sets the address counter to address CG RAM.

Once "Set CG RAM Address" has been executed, the contents of the address counter will be automatically modified after every access of CG RAM, as determined by the "7.4 Entry Mode Set" instruction. The active width of the address counter, when it is addressing CG RAM, is 6-bits so the counter will wrap around to 00H from 3FH if more than 64 bytes of data are written to CG RAM.

## 7.9 Set DD RAM Address

DB7	DB6	DB5	DB4	DB3	DB2	DB1	DB0	
1	ADD							

RS=0

80H to A7H (1 line), C0H to E7H (2 line)

This instruction

1. Loads a new 7-bit address into the address counter.
2. Sets the address counter to point to the DD RAM.

Once the "Set DD RAM Address" instruction has been executed, the contents of the address counter will be automatically modified after each access of DD RAM, as selected by the "7.4 Entry Mode Set" instruction.

Valid DD RAM Address (ADD) Range

	Number of Characters	Address
1st line	40	00H to 27H
2nd line	40	40H to 67H

### 7.10 Write Data

DB7	DB6	DB5	DB4	DB3	DB2	DB1	DB0
DATA WRITE							

00H to FFH  
RS=1

This instruction writes the data in DB7 to DB0 into either the CG RAM or the DD RAM. The RAM space (CG or DD), and the address in that space, that is accessed depends on whether a "Set CG RAM Address" or a "Set DD RAM Address" instruction was last executed, and on the parameters of that instruction. The contents of the address counter will be automatically modified after each "Write Data", as determined by the "7.4 Entry Mode Set". When data is written to the CG RAM, the DB7, DB6 and DB5 bits are not displayed as characters.

### 7.11 Read Data

DB7	DB6	DB5	DB4	DB3	DB2	DB1	DB0
DATA READ							

RS=1

This instruction reads data from either CG RAM or DD RAM, depending on the type of "Set RAM Address" instructions last sent. The address in that space depends on the "Set RAM Address" instruction parameters. Immediately before executing "Read Data", "Set CG RAM Address" or "Set DD RAM Address" must be executed. The contents of the address counter are modified after each "Read Data". As determined by the "7.4 Entry Mode Set". Display shift is not executed, as described at of the "7.4 Entry Mode Set".

### 7.12 Read Busy Flag/Address Counter

DB7	DB6	DB5	DB4	DB3	DB2	DB1	DB0
BF	ACC						

RS=0

Reading the instruction register yields the current value of the address counter and the busy flag. This instruction must be executed prior to any other instructions. ACC, the address counter value, will point to a location in either CG RAM or DD RAM, depending on the type of "Set RAM Address" instruction last sent.

In "Busy Flag Check" immediately after executing "Write Data" instruction, a valid address counter value can be ready as soon as BF goes low. The BF bit shows the status of the busy flag.

BF=1: busy.

BF=0: ready for next instruction, command receivable.

8 Other features

8.1 CG RAM

The display module has CG RAM of 320 bit = (5×8 bit /char) × 8 chars which is for user definable character fonts. The character fonts consist of 5×7 dots with underline. The number 1-36 corresponds to character fonts.

Character code	CG RAM address						CG RAM data (character pattern)							
	DB5	DB4	DB3	DB2	DB1	DB0	DB7	DB6	DB5	DB4	DB3	DB2	DB1	DB0
00H or (08H)	0	0	0	0	0	0	*	*	*	1	2	3	4	5
	0	0	0	0	0	1	*	*	*	6	7	8	9	10
	0	0	0	0	1	0	*	*	*	11	12	13	14	15
	0	0	0	0	1	1	*	*	*	16	17	18	19	20
	0	0	0	1	0	0	*	*	*	21	22	23	24	25
	0	0	0	1	0	1	*	*	*	26	27	28	29	30
	0	0	0	1	1	0	*	*	*	31	32	33	34	35
	0	0	0	1	1	1	*	*	*	36	0	0	0	0
01H or (09H)	0	0	1	0	0	0	*	*	*	1	2	3	4	5
	0	0	1	0	0	1	*	*	*	6	7	8	9	10
	0	0	1	0	1	0	*	*	*	11	12	13	14	15
	0	0	1	0	1	1	*	*	*	16	17	18	19	20
	0	0	1	1	0	0	*	*	*	21	22	23	24	25
	0	0	1	1	0	1	*	*	*	26	27	28	29	30
	0	0	1	1	1	0	*	*	*	31	32	33	34	35
	0	0	1	1	1	1	*	*	*	36	0	0	0	0

REMARKS; "\*" : Don't care. "0" : Turned off. "1" : Turned on.

Dot assignment

1	2	3	4	5
6	7	8	9	10
11	12	13	14	15
16	17	18	19	20
21	22	23	24	25
26	27	28	29	30
31	32	33	34	35
36				

Dot 36 is for underline.

## 8.2 Power-on reset

Internal status of the module is initialized, when the controller detects the rising of power supply up. The statuses are as follows:

1. Display clear  
Fills the DD RAM with 20Hex (Space code).  
During executing of "Display Clear" (Max. 100 $\mu$ s), the busy flag (BF) is "1".
2. Sets the address counter to 0H.  
Sets the address counter to point the DD RAM.
3. Display ON/OFF  
D=0: Display OFF  
C=0: Cursor OFF  
B=0: Blink OFF
4. Entry Mode Set  
I/D=1: Increment (+1)  
S=0: No display shift
5. Function Set  
IF=1: 8-bit interface
6. Brightness Control  
BR0=BR1=0: 100%

### Remarks

There is a possibility that reset doesn't work by slow start power supply.  
Therefore the initializing by commands needs.

## 8.3 CPU interface

The display module is capable to select some interfaces such as parallel (i80 or M68, 8-bit or 4-bit) or serial.

### 8.3.1 Select CPU

The module is able to select to parallel or serial data transfer by setting JP6 jumper, and to connect to bus of i80 type or M68 type CPU by setting JP2 jumper. Refer to "8.4 Jumper" for detail.

### 8.3.2 4-bit CPU interface

If 4-bit interface is used, the 8-bit instruction is written nibble by nibble: the high-order nibble being written first, followed by low-order nibble. It is not necessary to check the busy flag between writing separate nibbles of individual instructions.

Refer to "7.7.1 Function Set Command" for detail.

### 8.3.3 Serial data transfer

Serial data can be inputted when the Strobe goes to "0".

Serial data consists of 2 bytes. The first byte (Start Byte) consists of a total of 8 bits: the Synchronous bits (bit1-bit5), R/W (bit6), RS (bit7) and bit8. The register is selected (Instruction Register or Data Register) by the RS (bit7). RS is "0" in Instruction Register, and it is "1" in Data Register. The data write or read is selected by R/W (bit6). R/W is "0" when the data is written, and it is "1" when the data is read.

	0	1
R/W	Data Write	Data Read
RS	Instruction Register	Data Register

In "Data Write", the second byte (8-bit Instruction / Data Byte) is written after the Start Byte. On the other hand, the second byte is the read data in "Data Read", such as the Busy Flag + Address Counter or the data written in the DD RAM or CG RAM. The read data is outputted at the falling edge of the shift clock.

<Data Write>

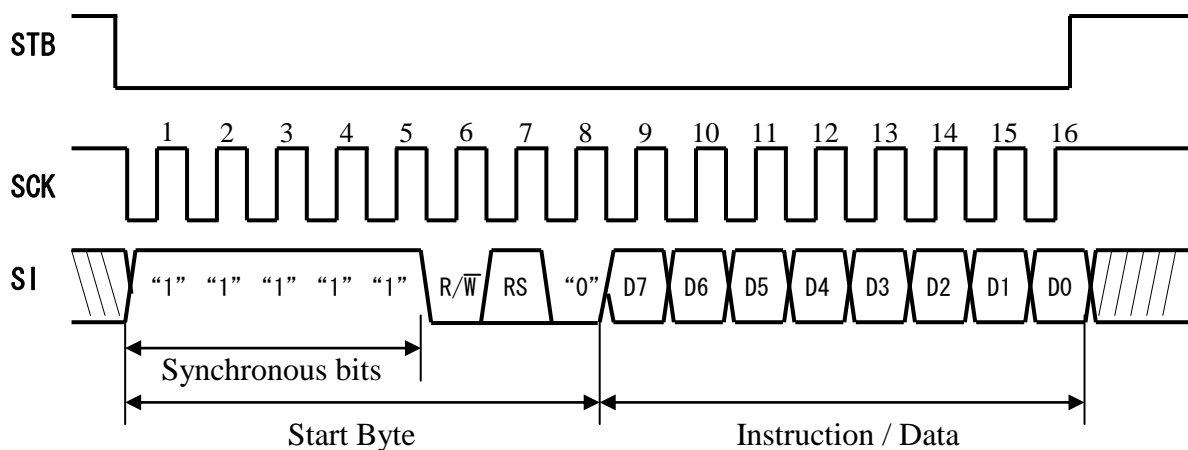

<Data Read>

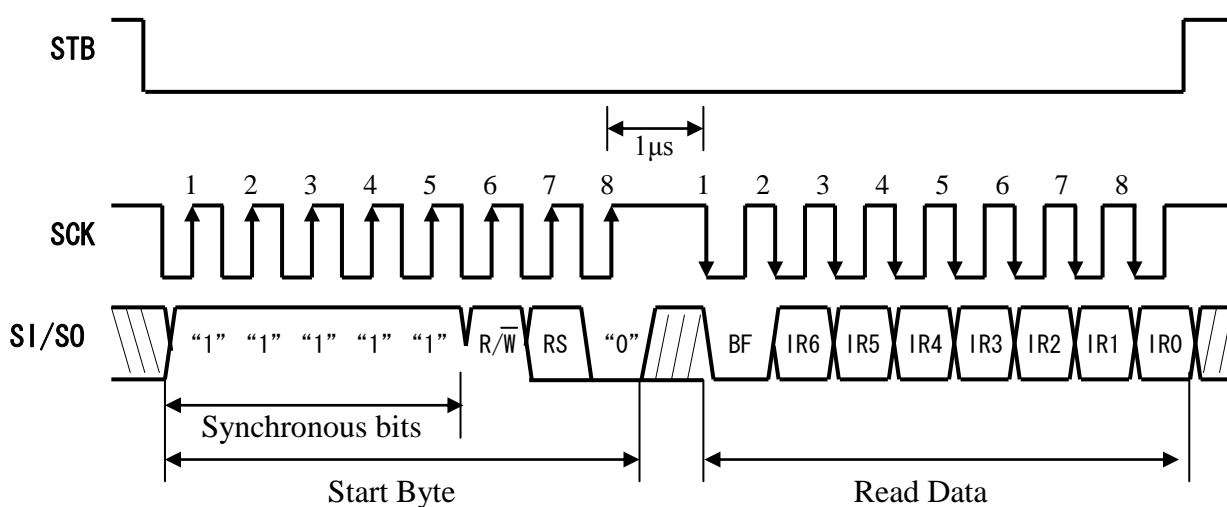

### 8.4 Jumper

Some jumpers are prepared on the PCB board, to set operating mode of the display module.

A soldering iron is required to short jumper.

No.2 and No.3 of jumper 'JP1' are used to reset of module.

You can reset the module by shorting No.2 and No.3 of the jumper 'JP1' for some interval which is longer than 10μs.

The following figure shows the location of each jumper.

Location

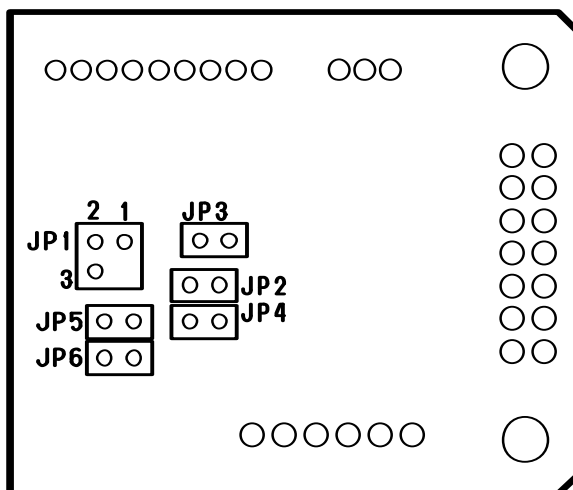

The following table shows the function of No.1 and No.2 of JP1, JP2, JP5 and JP6.

Default setting is no external reset inputs, M68 CPU bus parallel interface and Katakana font.

External reset input signal is active when it is low.

Table of No.1 and No.2 of JP1 setting

No.1 and No.2 of JP1	No.3 of CN1 and No.6 of CN3
open	NC
short	$\overline{\text{RESET}}$

NC: no connection

Table of JP6 setting

JP6	Interface
open	Parallel interface
short	Serial interface

Table of JP2 setting

JP2	CPU bus mode	Control signals
open	M68 type	$\overline{\text{E,R/W}}$
short	i80 type	$\overline{\text{WR, RD}}$

Table of JP5 setting

JP5	Character font
open	Katakana font
short	International font

JP3 and JP4 are factory use only.

9 Character Font

Note: Font number 00-07Hex (08-0FHex) is User Definable Character Fonts.

9.1 Katakana character font

	D7	0	0	0	0	0	0	0	1	1	1	1	1	1	1		
	D6	0	0	0	0	1	1	1	1	0	0	0	1	1	1		
	D5	0	0	1	1	0	0	1	1	0	0	1	1	0	1		
	D4	0	1	0	1	0	1	0	1	0	1	0	1	0	1		
3210	DDDD	0	1	2	3	4	5	6	7	8	9	A	B	C	D	E	F
0000	0			0	0	P	\	P	Ä	E		-	ウ	三	α	P	
0001	1		!	1	A	Q	a	9	á	e	u	フ	チ	△	△	9	
0010	2		"	2	B	R	b	r	Á	E	F	イ	ウ	ノ	β	θ	
0011	3		#	3	C	S	c	s	Á	R	↓	ウ	テ	E	ε	∞	
0100	4		\$	4	D	T	d	t	á	®	\	I	ト	ト	μ	∞	
0101	5		%	5	E	U	e	u	E	∞	∞	オ	ナ	∞	∞	∞	
0110	6		&	6	F	V	f	v	∞	∞	∞	ヲ	カ	∞	∞	∞	
0111	7		'	7	G	W	g	w	∞	∞	∞	フ	チ	フ	ウ	π	
1000	8		<	8	H	X	h	x	∞	∞	∞	∞	ナ	リ	∞	∞	
1001	9	♪	)	9	I	V	i	v	∞	∞	∞	∞	∞	∞	∞	∞	
1010	A	∞	*	∞	J	Z	j	z	∞	∞	∞	∞	∞	∞	∞	∞	
1011	B	∞	+	∞	K	L	k	l	∞	∞	∞	∞	∞	∞	∞	∞	
1100	C	∞	,	<	L	¥	l	l	\	∞	∞	∞	∞	∞	∞	∞	
1101	D	∞	-	=	M	I	m	)	∞	∞	∞	∞	∞	∞	∞	∞	
1110	E	∞	.	>	N	^	n	∞	∞	∞	∞	∞	∞	∞	∞	∞	
1111	F	∞	/	?	∞	∞	∞	∞	∞	∞	∞	∞	∞	∞	∞	∞	

Font: G57131.cg



9.2 International character font

					D7	0	0	0	0	0	0	0	1	1	1	1	1	1	1	1	
					D6	0	0	0	0	1	1	1	1	0	0	0	0	1	1	1	1
					D5	0	0	1	1	0	0	1	1	0	0	1	1	0	0	1	1
					D4	0	1	0	1	0	1	0	1	0	1	0	1	0	1	0	1
D	D	D	D		0	1	2	3	4	5	6	7	8	9	A	B	C	D	E	F	
3	2	1	0		0	1	2	3	4	5	6	7	8	9	A	B	C	D	E	F	
0	0	0	0	0				0	a	P	`	p	U	i	i	i	i	i	i		
0	0	0	1	1			!	1	A	Q	a	q	Δ	4	i	i	ä	Ä	ä	Ä	
0	0	1	0	2			"	2	B	R	b	r	ß	W	ä	Ä	ø	Ø	e	ä	
0	0	1	1	3			#	3	C	S	c	s	À	W	á	Á	â	Â	ÿ	Ä	
0	1	0	0	4			\$	4	D	T	d	t	É	b	à	À	ü	Ü	ó	Ó	
0	1	0	1	5			%	5	E	U	e	u	Ŋ	W	ú	Ú	û	Û	ü	Ü	
0	1	1	0	6			&	6	F	V	f	v	Σ	b	ò	Ò	ë	É	è	È	
0	1	1	1	7			'	7	G	W	g	w	ϕ	ø	é	É	ê	Ê	ë	È	
1	0	0	0	8			(	8	M	X	h	x	ϕ	W	è	È	é	É	ë	È	
1	0	0	1	9			)	9	I	Y	i	y	Q	9	ç	Ç	ç	Ç	ç	Ç	
1	0	1	0	A			*	:	J	Z	j	z	È	À	ì	Ì	Ë	Ê	Ë	Ê	
1	0	1	1	B			+	:	K	I	k	‹	À	É	ð	Ð	´	Ç	Þ		
1	1	0	0	C			,	<	L	\	l		Ŋ	ß	ç	Ç	ç	Ç	ç	Ç	
1	1	0	1	D			-	=	M	I	m	>	È	ß	ž	Ž	ñ	Ñ	ñ	Ñ	
1	1	1	0	E			.	>	N	^	n	÷	M	K	ò	æ	Æ	ñ	ñ	ë	
1	1	1	1	F			/	?	O	_	o	÷	Ŋ	U	ò	ó	ö	ó	ö	■	

Font: G57206.cg

10 Timing

Input signal rise time and fall time < 15 ns.

10.1 CPU bus write timing (Parallel interface i80 type)

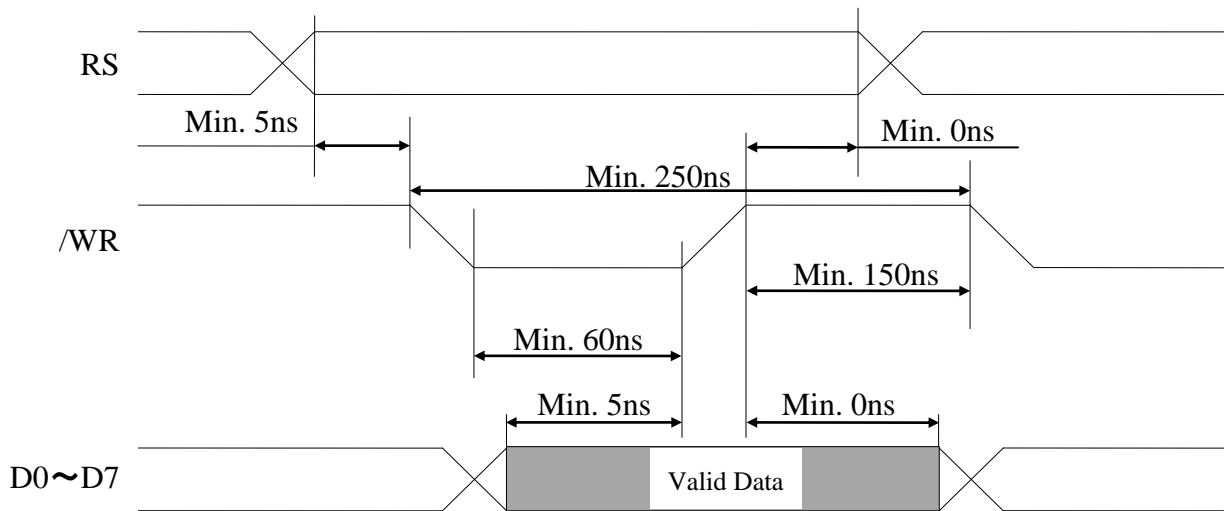

10.2 CPU bus read timing (Parallel interface i80 type)

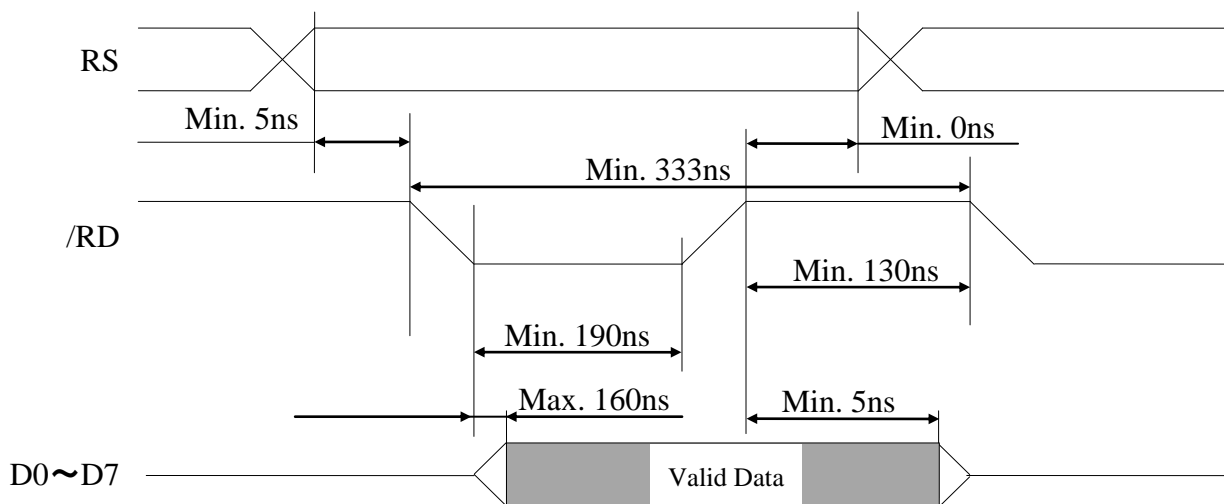

10.3 CPU bus write timing (Parallel interface M68 type)

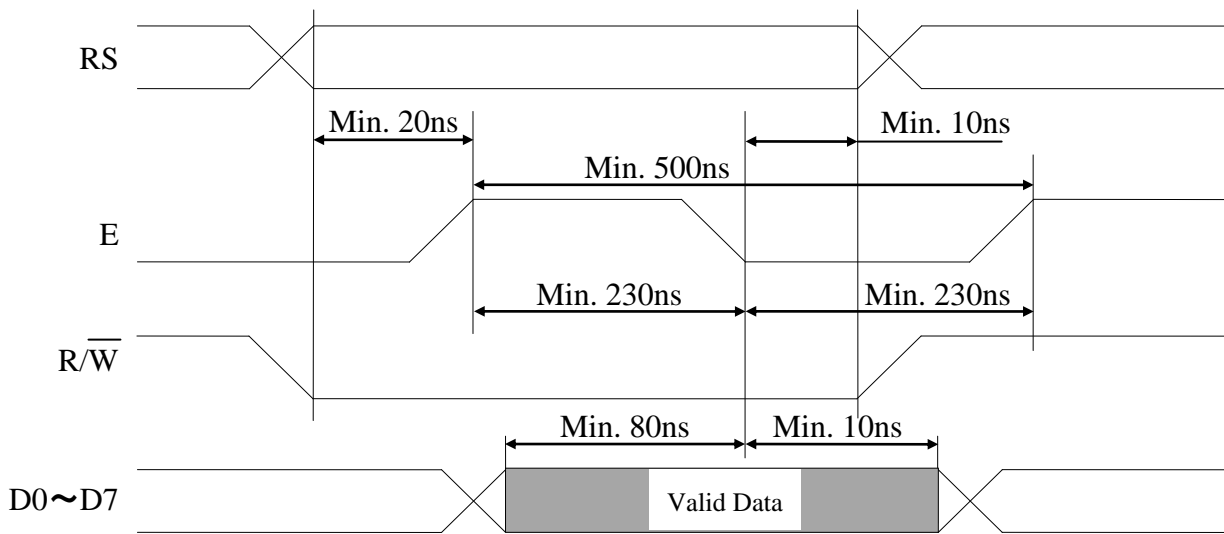

10.4 CPU bus read timing (Parallel interface M68 type)

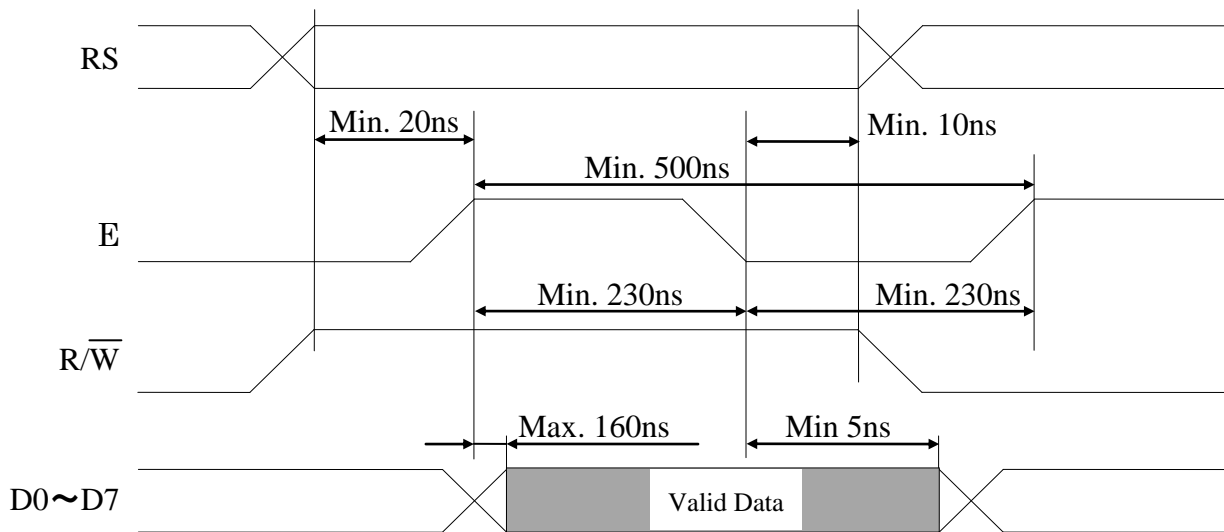

10.5 Write timing (Serial interface)

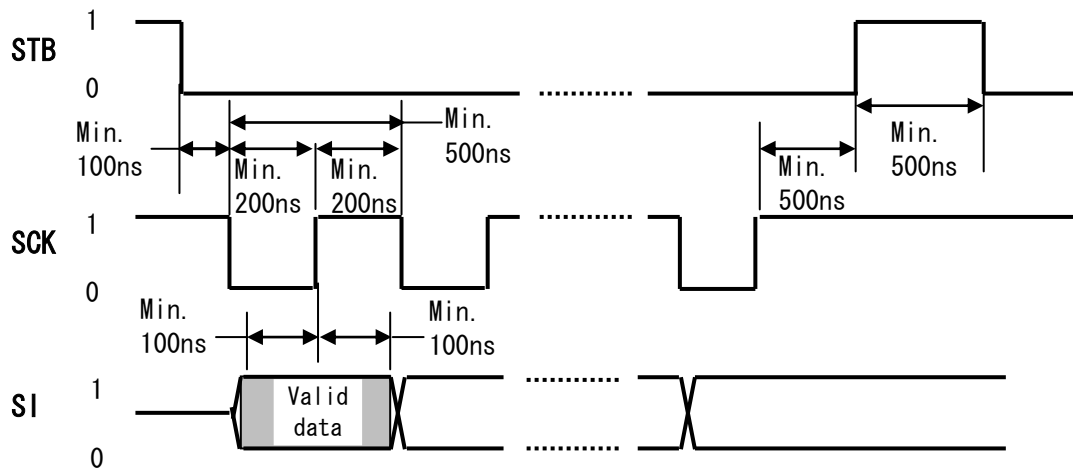

10.6 Read timing (Serial interface)

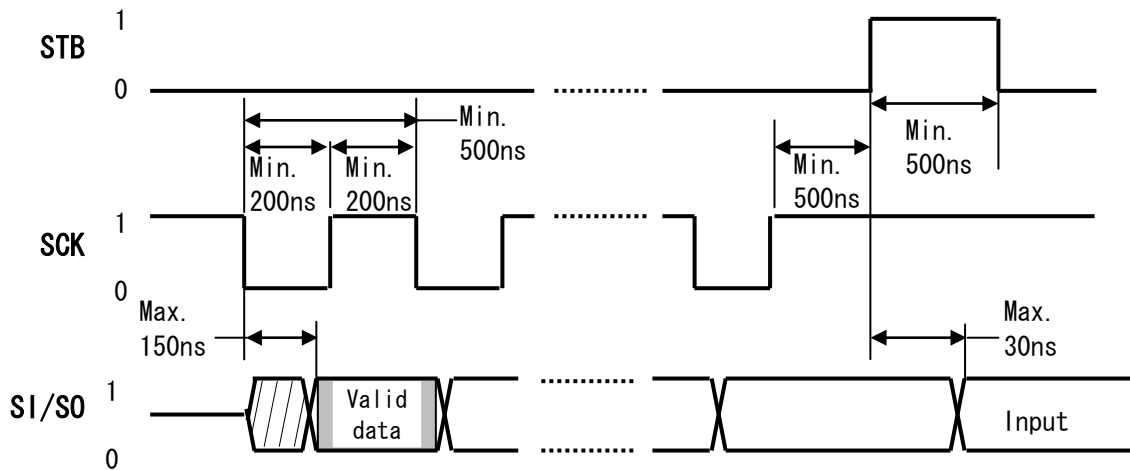

## 11 Connector Pin assignment

The through holes are prepared for power supply and data communications.  
A connector or pins may be able to solder to the holes.

Diameter of holes is 1.0mm.

### 11.1 14pin Connector (CN1) for parallel interface

Pin No.	Signal name	Function	Direction
1	GND	Ground	Input
2	VCC	Power supply	Input
3	NC *	Non connection	-
4	RS	Switch signal	Input
5	R/W(WR)	Data transfer select (Write enable)	Input
6	E(RD)	Write enable (Read enable)	Input
7	DB0	Data input/output	Input/Output
8	DB1	Data input/output	Input/Output
9	DB2	Data input/output	Input/Output
10	DB3	Data input/output	Input/Output
11	DB4	Data input/output	Input/Output
12	DB5	Data input/output	Input/Output
13	DB6	Data input/output	Input/Output
14	DB7	Data input/output	Input/Output

\*: The third through hole is for reset input when No.1 and No.2 of JP1 are short.

(): At the i80 type.

### 11.2 6pin Connector (CN3) for serial interface

Pin No.	Signal name	Function	Direction
1	VCC	Power supply	Input
2	SI/SO	Data input/output	Input/Output
3	GND	Ground	Input
4	STB	Strobe	Input
5	SCK	Display clock	Input
6	NC *	Non connection	-

\*: The 6th through hole is for reset input when No.1 and No.2 of JP1 are short.

12 Outline dimension

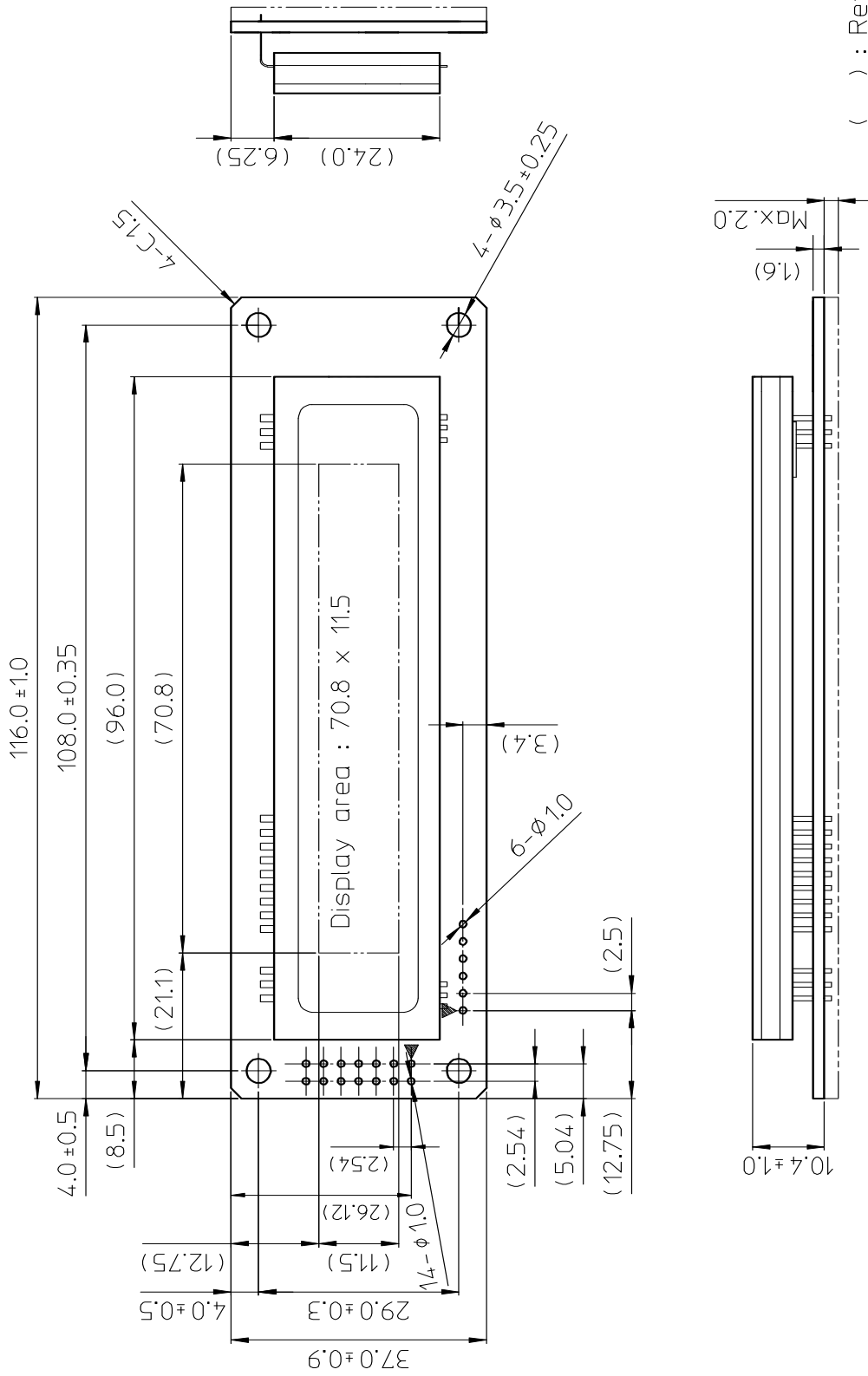

## Notice for the Cautious Handling VFD Modules

### Handling and Usage Precautions:

Please carefully follow the appropriate product application notes for proper usage, safety handling, and operation standards for maximum performance.

#### [VFD tubes are made of glass]

- Because the edges of the VFD glass-envelop are not smooth, it is necessary to handle carefully to avoid injuries to your hands.
- Please avoid breaking the VFD glass-envelop to prevent injury from sharp glass particles.
- The tip of the exhaust pipe is fragile so avoid shock from impact.
- It is recommended to allow sufficient open space surrounding the exhaust pipe to avoid possible damage.
- Please design the PCB for the VFD-module within 0.3 mm warping tolerance to avoid any forces that may damage the display due to PCB distortion causing a breakdown of the electrical circuit leading to VFD failure.

#### [High voltage]

- Avoid touching conductive electrical parts, because the VFD-module uses high voltage exceeding 30~100 volts.
- Even when electric power is turned off, it may take more than one minute for the electrical current to discharge.

#### [Cable connection]

- Do not unplug the power and/or data cables of VFD-modules during operating condition because unrecoverable damage may result.
- Sending input signals to the VFD-module during a power off condition sometimes causes I/O port damage.
- It is recommended to use a 30 cm or shorter signal cable to prevent functional failures.

#### [Electrostatic charge]

- VFD-modules need electrostatic free packaging and protection from electrostatic charges during handling and usage.

#### [Structure]

- During operation, VFD and VFD-modules generate heat. Please consider sufficient heat radiation dissipation using heat sink solutions.
- We prefer to use UL grade materials or components in conjunction with VFD-modules.
- Wrap and twist motion causes stress and may break VFDs & VFD modules. Please adhere to allowances within 0.3mm at the point of attachment.

#### [Power]

- Apply regulated power to the VFD-module within specified voltages to protect from failures.
- Because some VFD-modules may consume in rush current equal to twice the typical current at power-on timing, we recommend using a sufficient power capability and quick starting of the power regulator.
- VFD-module needs a specified voltage at the point of connection. Please use an adequate power cable to avoid a decrease in voltage. We also recommend inserting a power fuse for extra protection.

#### [Operating consideration]

- Illuminating phosphor will decrease in brightness during extended operation. If a fixed pattern illuminates for an extended period (several hours), the phosphor efficiency will decrease compared to the non operating phosphor causing a non uniform brightness among pixels. Please consider programming the display patterns to use all phosphor segments evenly. Scrolling may be a consideration for a period of time to refresh the phosphor condition and improve even illumination to the pixels.
- We recommend using a signal cable 30cm or less to avoid some possible disturbances to the signal.

#### [Storage and operating environment]

- Please use VFD-modules under the recommended specified environmental conditions. Salty, sulfur and dusty environments may damage the VFD-module even during storage.

#### [Discard]

- Some VFDs contain a small amount of cadmium in the phosphor and lead in the solder. When discarding VFDs or VFD-modules, please adhere to governmental related laws or regulations.  
(Note: RoHS-compliant products do not contain cadmium)

#### [Others]

- Although the VFD-module is designed to be protected from electrical noise, please plan your circuitry to exclude as much noise as possible.
- Do not reconstruct or repair the VFD-module without our authorization. We cannot assure the quality or reliability of unauthorized reconstructed VFD-modules.

#### Notice:

- We do not authorize the use of any patents that may be inherent in these specifications.
- Neither whole nor partial copying of this specification is permitted without our approval.  
If necessary, please ask for assistance from our sales consultant.
- This product is not designed for military, aerospace, medical or other life-critical applications. If you choose to use this product for these applications, please ask us for prior consultation or we cannot take responsibility for problems that may occur.